

DUMPSTER ENCLOSURE SINGLE NON-TRAFFIC BEARING

CITY INDEX NO. 701; 1 OF 3
N.T.S.

				CITY OF CLEARWATER, FLORIDA ENGINEERING DEPARTMENT	
				REDRAWN BY E.A.	DUMPSTER ENCLOSURE
				CHECKED BY D.M.	SINGLE
				APPROVED BY T.G.	NON-TRAFFIC BEARING
REV.	DATE	DESCRIPTION	APP.		DATE 08/09
					INDEX NO. 701
					1 OF 3

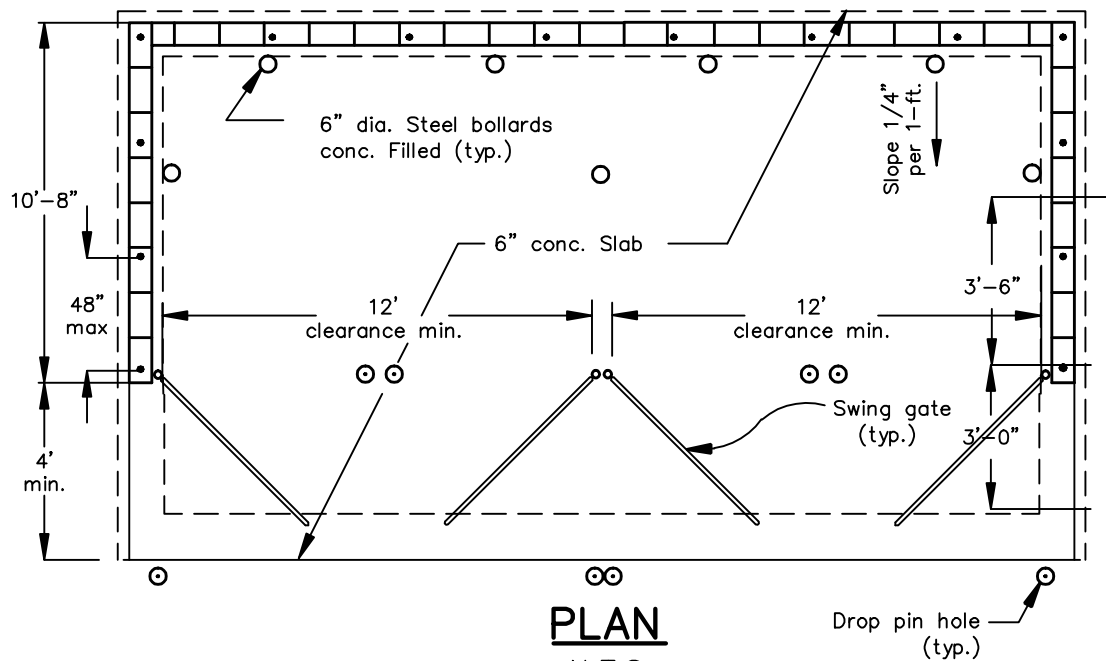

PLAN
N.T.S.

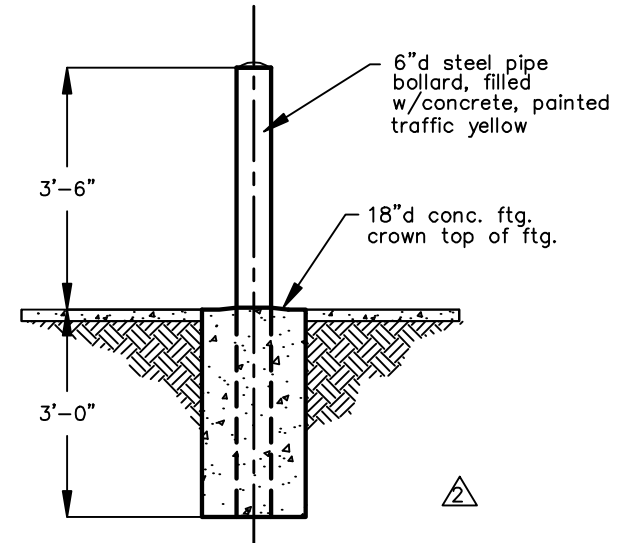

BOLLARD DETAIL
N.T.S.

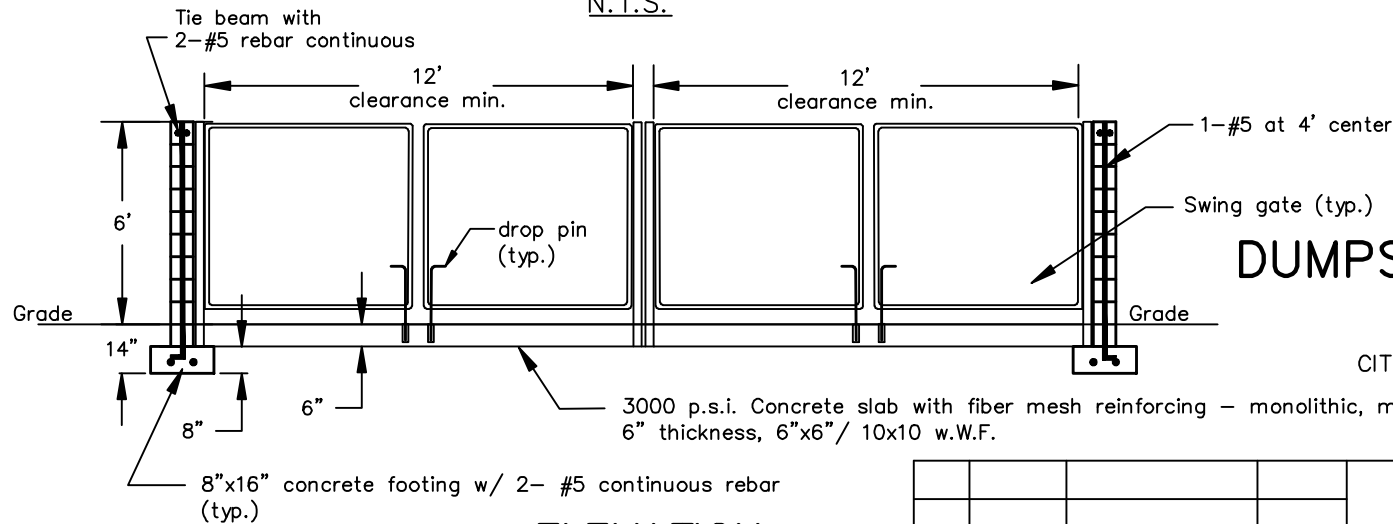

ELEVATION
N.T.S.

**DUMPSTER ENCLOSURE
DOUBLE**

CITY INDEX NO. 701; 2 OF 3
N.T.S.

				CITY OF CLEARWATER, FLORIDA ENGINEERING DEPARTMENT	
				REDRAWN BY E.A.	DUMPSTER ENCLOSURE
				CHECKED BY D.M.	DOUBLE
				APPROVED BY T.G.	
REV.	DATE	DESCRIPTION	APP.		DATE 08/09
					INDEX NO. 701
					2 of 3

NOTES:

1.) WALLS

a.) New construction: maximum 6'-0" high and constructed of concrete block (8"x8"x16"). Materials used should be consistent with those used in the construction of and architectural style of the principal building. (Section 3-802 Materials)

b.) Existing: maximum 6'-0" high replacement materials can be made of the same materials as long as they are made of approved opaque material.

2.) FOOTINGS

8"x16" concrete w/2- #5 continuous rebar imbedded.

3.) CONCRETE SLAB

Monolithic, min. 6" thickness w/imbedded 6"x6"/ 10x10 welded wire fabric (W.W.F.), 3000 P.S.I. with fiber mesh reinforcing.

4.) CONCRETE FILLED CELLS

With 1-#5 vertical rebar tied to footer steel at each corner and every 4' O.C.

5.) GATES

Constructed of min. 1-1/2" diameter galvanized tubular steel w/privacy-type slats inserted in galvanized steel mesh fabric, hinge-mounted on min. 3" diameter galvanized steel post. (Gates and post constructed and installed per applicable building code by licensed fence contractor).

6.) DROP PIN

1/2" dia. 18" long metal rod gate latch. Provide 3/4" dia. hole 6" into concrete for rods. In asphalt provide a 3/4" P.V.C. sleeve, 6" long, or equal.

7.) SOIL

Soil bearing capacity to be at least 2,500 P.S.F.

8.) BOLLARD

3'-6" high, 6" diameter steel pipe bollard filled with concrete, painted traffic yellow, imbedded 3'-0" deep in 18" concrete foundation. (See Detail)

CONCRETE MASONRY WALL CONSTRUCTION

Materials, construction and quantity control of masonry shall be in accordance with Uniform Building Code (UBC), Chapter 24. General conditions and construction requirements shall be applied as specified in UBC, Section 2404 (f), during grouted masonry work.

1. All reinforcing steel shall be deformed bars conforming to ASTM A-615, Grade 60. Vertical reinforcement shall be placed in the center of the masonry cell, and shall be held in position at the top and bottom.

2. If a slab dowel does not line-up with a vertical core, it shall not be sloped more than one horizontal in six verticals (1:6).

3. Horizontal wall reinforcement shall be standard truss type DUR-O-WALL (or equivalent) at 16' o.c..

4. Hollow Load-bearing Concrete Masonry Units shall be normal weight conforming to ASTM C-90, with a minimum compressive strength of 1,900 PSI.

5. Mortar shall be type M or S, in accordance with ASTM C-270. Place all masonry in running bond with 3/8" mortar joints. Provide complete coverage face shell mortar bedding, horizontal and vertical.

6. Coarse grout shall conform to ASTM C-476, with a maximum aggregate size of 3/8", 8" to 10" slump, and a minimum compressive strength of 2,500 PSI at 28 days.

7. Minimum 3" X 3" clean-out holes (saw-cut) are required at the bottom course of all cells to verify grout placement. Clean-outs shall be sealed after masonry inspection-provided in accordance with ACI 531-4.6, and before grouting.

8. Prior to grouting, the grout space shall be clean, with no mortar projections greater the 1/2", mortar droppings or other foreign material. All cells shall be in vertical alignment, and shall solidly be filled with coarse grout as specified.

9. During placing, grout shall be consolidated with flexible cable vibrator. First grout pour shall be stopped a minimum of 1 - 1/2" below the top of the middle bond beam masonry.

DUMPSTER ENCLOSURE NOTES

CITY INDEX NO. 701; 3 OF 3

				CITY OF CLEARWATER, FLORIDA ENGINEERING DEPARTMENT		
				REDRAWN BY E.A.		DATE 08/09
				CHECKED BY D.M.	DUMPSTER ENCLOSURE	INDEX NO. 701
				APPROVED BY T.G.	NOTES	
REV.	DATE	DESCRIPTION	APP.			3 OF 3